

2M218J

ELECTRICAL SPECIFICATION

This specification is based upon EIAJ ED-1501 Testing Methods for Continuous Wave Magnetrons

DAEWOO CONTINUOUS WAVE MAGNETRON 2M218J

DESCRIPTION	Magnetron (Fixed Frequency, Integral Magnet)									
FUNCTION	For Microwave Oven (2450MHz Band continuous wave oscillation)									
OUTER DIMENSIONS	See Outline drawing									
ABSOLUTE MAXIMUM RATINGS									NOTE(4)(5)	NOTE(4)
	TERM	Ef	tk	Ebm	Ib	Ibm	Pin	σL	T _p	T _{case}
	UNIT	V	sec	kV	mAdc	A	kW	-	℃	℃
	MAX.	3.75	-	4.5	350	1.2	1.4	4	300	100
	MIN.	2.80	0	-	-	-	-	-	-	-
STANDARD TEST CONDITION	NOTE (1)(2)(3)	3.30	-	-	300	-	-	1.1MAX	-	-

TEST SPECIFICATION

TEST TERM NOTE (8)	TEST METHOD EIAJ ED-1501	TEST CONDITION	SYMBOL	BOGIE	LIMIT		UNIT	
					MIN.	MAX.		
** VIBRATION	5.4.1		-	-	-	-	-	
* BREAK DOWN VOLTAGE	4.2	NOTE (6)	-	-	-	-	-	
* INSULATION	4.2	Eb=1kVdc R.H.MAX.60%	-	-	100	-	MΩ	
* FILAMENT CURRENT	4.1.1	tk=120sec	If	10	8	12	A	
PEAK ANODE VOLTAGE	4.3.1	NOTE (7)	Ebm	4.10	3.95	4.25	kV	
AVERAGE POWER OUTPUT (1)	4.3.3.1	NOTE (7)	Po (1)	925	885	965	W	
FREQUENCY	4.3.4		f	2458	2448	2468	MHz	
** PULLING FIGURE	4.3.6	σL = 1.5	fpl	-	-	15	MHz	
** SINK PHASE	4.3.7		λ _{sink} /λ _g	0.25	-	-	-	
* STABILITY MODING (1)	4.3.11.2	σL = 2,3,4; t = 60sec	-	-	-	-	-	
* FUNDAMENTAL FREQUENCY RADIATION	4.3.15	σL = 4	S1	-	-	1	mW/cm ²	
** LIFE TEST	4.5.1		t	-	500	-	hour	
** LIFE TEST END POINT	AVERAGE POWER OUTPUT (1)	4.3.3.1	NOTE (7)	Po (1)	-	710	-	W

SPEC. NO. :

DATE :

PAGE : 2 / 10

UNIT: mm

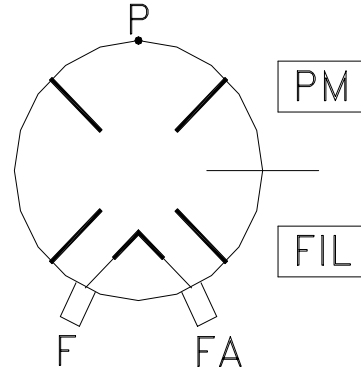
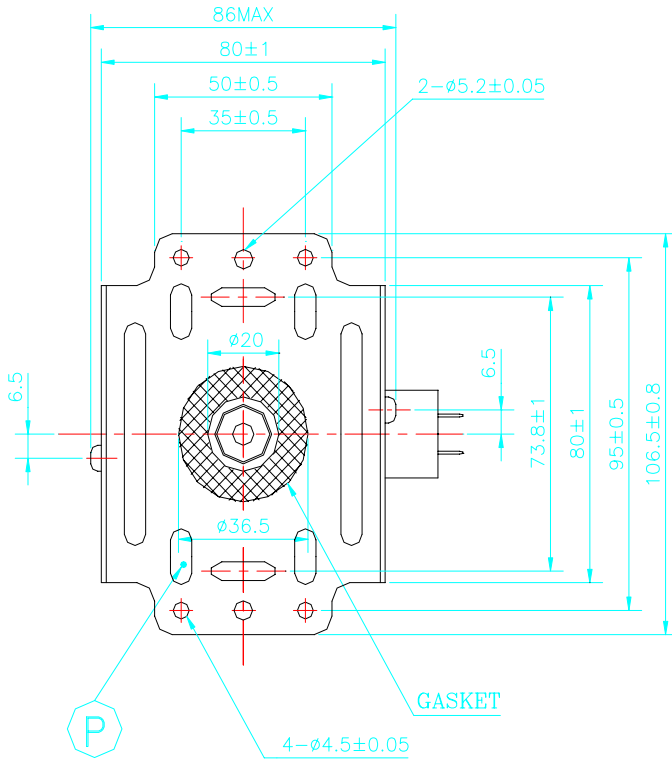

NOTE<1> TEMPERATURE TO BE MEASURED AT THE OUTLET SIDE OF AIRFLOW.

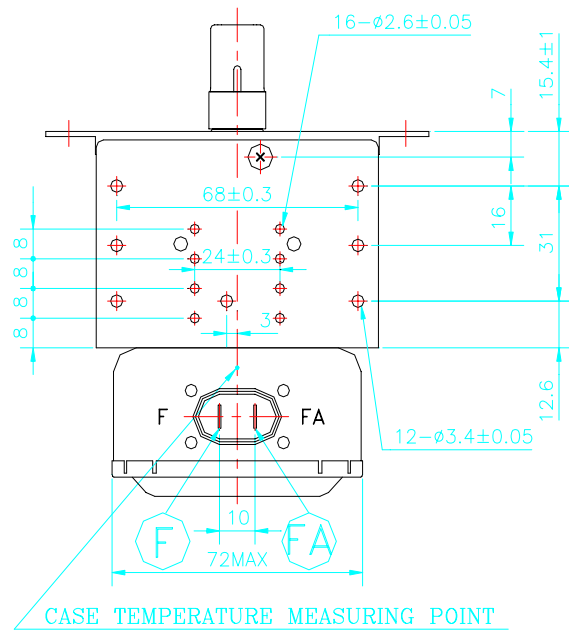
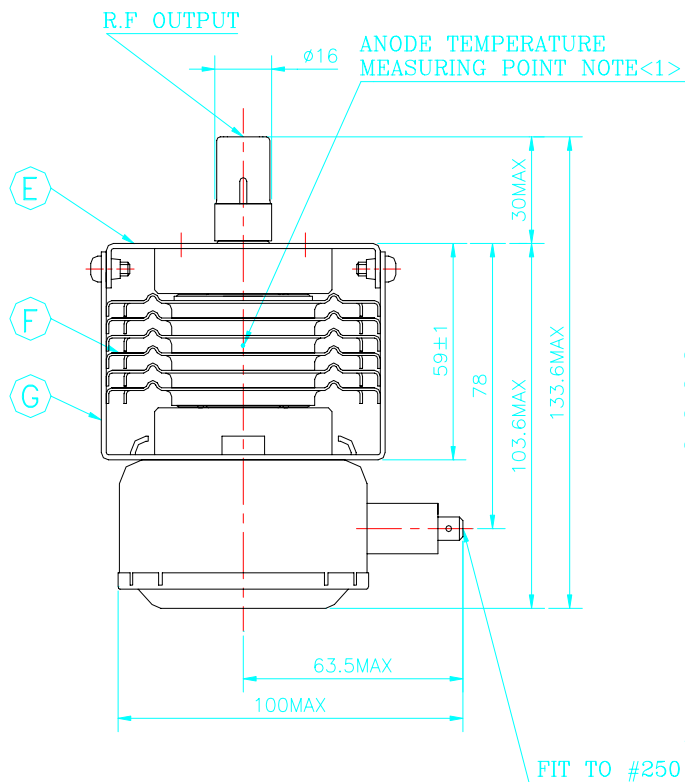

FIT TO #250 FASTON RECEPTACLE